



# MODEL ZEPHAIRE-G

Full-size Gas Convection Oven



ZEPHAIRE-G

Project \_\_\_\_\_

Item No. \_\_\_\_\_

Quantity \_\_\_\_\_

Extra depth baking compartment - accepts five 18" x 26" standard full-size baking pans in left-to-right or front-to-back positions.

All data is shown per oven section, unless otherwise indicated.

### EXTERIOR CONSTRUCTION

- Full angle iron frame
- Stainless steel front, top, and sides
- Solid independent stainless steel doors
- Chrome-plated door handles with independent door operation
- Triple-mounted door hinge pins
- Removable front control panel
- Solid mineral fiber insulation at top, back, sides and bottom

### INTERIOR CONSTRUCTION

- Double-sided porcelainized baking compartment liner (14 gauge)
- Aluminized steel combustion chamber
- Dual inlet blower wheel
- Five chrome-plated racks, eleven rack positions with a minimum of 1-5/8" (41mm) spacing

### OPERATION

- Dual Flow Gas system combines direct and indirect heat
- Electronic spark ignition control system
- Removable dual tube burners
- Pressure regulator and manual gas service cut-off valve located in front control area
- Air mixers with adjustable air shutters
- Solid state thermostat with temperature control range of 200°F (93°C) to 500°F (260°C)
- Single speed fan motor
- 1/3 horsepower blower motor with automatic thermal overload protection
- Control area cooling fan

### STANDARD FEATURES

- Solid state manual controls with separate dials for thermostat and timer
- 60 minute electric timer with buzzer
- One year parts and labor oven warranty\*
- Three year limited oven door warranty\*

\* For all international markets, contact your local distributor.

### OPTIONS AND ACCESSORIES

(AT ADDITIONAL CHARGE)

- **Legs/casters:**
  - 6" (152mm) stainless steel legs
  - 6" (152mm) seismic legs
  - 6" (152mm) casters
  - 4" (107mm) low profile casters
  - 25" (635mm) stainless steel legs
- **Venting:**
  - Draft diverter
  - Draft hood
- **Gas hose with quick disconnect and restraining device:**
  - 48" (1219mm) hose
  - 36" (914mm) hose
- Open stand with rack guide, stainless steel
- Base cabinet
- Extra oven racks
- Gas manifold (for double sections)
- Stainless steel solid back panel
- Plus package (dependent glass doors, interior lights and a two speed motor)
- Flue connector
- Extended warranty



### BLODGETT OVEN COMPANY

www.blodgett.com

44 Lakeside Avenue, Burlington, VT 05401

Toll Free: (800) 331-5842 • Phone: (802) 860-3700 • Fax: (802) 864-0183



# MODEL ZEPHAIRE-G

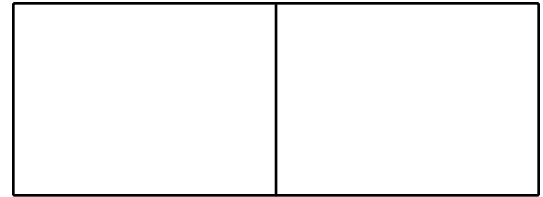

APPROVAL/STAMP

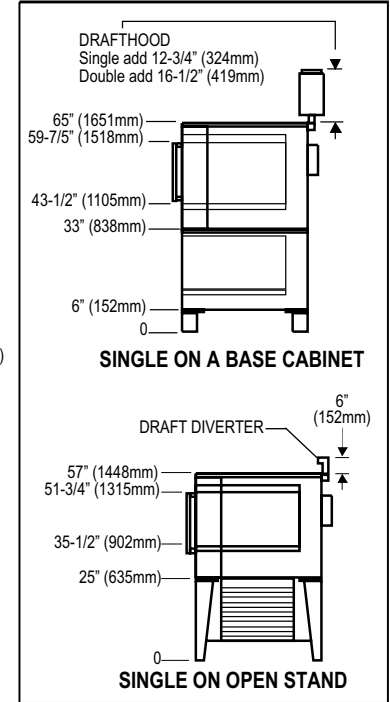
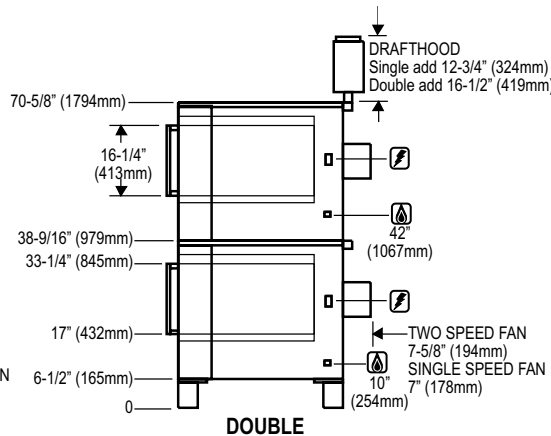
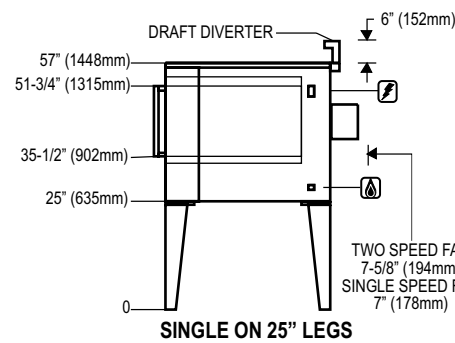
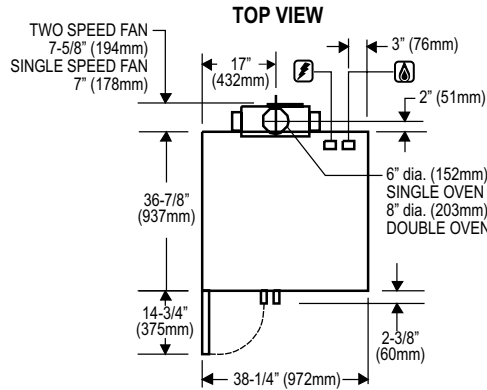

### SHORT FORM SPECIFICATIONS

Provide Blodgett full-size convection oven model ZEPHAIRE-G, (single/double) compartment. Each compartment shall have porcelainized steel liner and shall accept five 18" x 26" standard full-size bake pans in left-to-right or front-to-back positions. Doors shall be solid stainless steel with chrome plated handles and independent operation. Unit shall be gas heated with electronic spark ignition and shall cook by means of a dual-flow system combining direct and indirect heat. Air in baking chamber distributed by dual inlet blower wheel powered by a single-speed, 1/3 HP motor with thermal Overload protection. Each chamber shall be fitted with five chrome-plated removable racks. Control panel shall be recessed with Cook/Cool Down mode selector, solid state manual infinite thermostat (200 - 500°F), and 60-minute timer. Provide options and accessories as indicated.

### DIMENSIONS:

- Floor space** 38-1/4" (972mm) W x 36-7/8" (936mm) L
- Product clearance** 6" from combustible and non-combustible construction.
- Interior** 29" (737mm) W x 20" (508mm) H x 28-1/4" (718mm) D
- If oven is on casters add to all height dimensions:**
- Single 4-1/2" (114mm)
- Double 2-1/4" (57mm)

### GAS SUPPLY:

- 3/4" IPS connection at rear of oven
- Manifold Pressure:
- Natural – 3.5" W.C. • Propane – 10" W.C.
- Inlet Pressure:
- Natural – 7.0" W.C. min. – 10.5" W.C. max.
- Propane – 10.5" W.C. min. – 13.0" W.C. max.

### MAXIMUM INPUT:

- Single 60,000 BTU/hr (17.6 Kw)
- Double 120,000 BTU/hr (35.2 Kw)

### POWER SUPPLY:

- 115 VAC, 1 phase, 6 Amp, 60 Hz., 2-wire with ground, 1/3 H.P., 1 speed motor, 1725 RPM (two speed optional)
- 230, 220/240VAC, 1 phase, 3 Amp, 50 Hz., 2-wire with ground, 1/3 H.P., 1 speed motor, 1425 RPM
- 6' (1.8m) electric cord set furnished on 115 VAC ovens only.

### MINIMUM ENTRY CLEARANCE:

- Uncrated 32-1/16" (814mm)
- Crated 37-1/2" (953mm)

### SHIPPING INFORMATION:

- Approx. Weight:** Crated                      Uncrated
- Single:                      545 lbs. (248 kg)    460 lbs. (208 kg)
- Double:                      1050 lbs. (476 kg)    920 lbs. (416 kg)

### Crate sizes:

37-1/2" (952mm) x 43-1/2" (1105mm) x 52" (1321mm)

**NOTE:** The company reserves the right to make substitutions of components without prior notice

### BLODGETT OVEN COMPANY

www.blodgett.com

44 Lakeside Avenue, Burlington, VT 05401

Toll Free: (800) 331-5842 • Phone: (802) 860-3700 • Fax: (802) 864-0183