

HOSHIZAKI

DM-180A
Item # 13051
4/04

DM-180A SERIES



**DM-180A Counter Top
Ice Dispenser**

DM-180A
DM-180A - Ice
Dispenser
Optional Water Valve

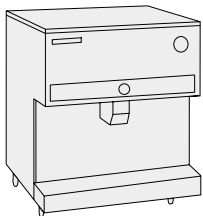

DM-180A

DIMENSION

Width x Depth x Height

DM-180A

30 x 30 x 36 1/2"
Height includes 4" legs

- Manual fill ice dispenser
- Has a 30" wide body
- Corrosion resistant stainless steel
- Unique auger agitator design dispenses individual cubes and has been proven on the hotel market
- Ice storage capacity of 180 lbs.
- Fills large cups quickly
- Optional water supply valve for dispensing water

ICE DISPENSER



Reliability is a
beautiful thing™



© HOSHIZAKI AMERICA, INC.

618 Hwy. 74 S., Peachtree City, GA 30269

1-800-438-6087

FAX 1-800-345-1325

TEL 770-487-2331

www.hoshizaki.com

ICE DISPENSER



DM-180A (ICE DISPENSER WITH OPTIONAL WATER VALVE)

- Fills large cups quickly
- 180 lbs. of built-in ice storage
- Optional water supply valve for dispensing water

WARRANTY TWO YEAR - Parts & Labor on Dispenser	STAINLESS STEEL INTERNAL AUGER	SERVICE Panels easily removed and all components accessible for service.
	DRAINS 1" ID Vinyl Hose	

Warranty valid in United States, Canada, Puerto Rico, & U.S. Territories. Contact Factory for Warranty in other Countries.

OPERATING LIMITS Ambient Temp Range 45 - 100°F Voltage Range 104 - 132V	A/C SUPPLY VOLTAGE 115-120/60/1	STORAGE BIN Insulated Built-in 180 lb. capacity	OPTIONS 4" Leg Kit Water Valve DM Top Kit to accommodate machines
		ELECTRIC CONSUMPTION Approx. 190W	

SPECIFICATIONS			
Model Number	Amperage	Min Circuit Ampacity	Shipping Weight
DM-180A	1.5A	15A	240 lbs.

The unique curved shape of Hoshizaki Crescent Cube ice allows liquid to flow over it more easily whether pouring from bottles or dispensers, so there is less waste and no messy splashing. The crystal clear cube also has excellent displacement qualities because of the unique shape.

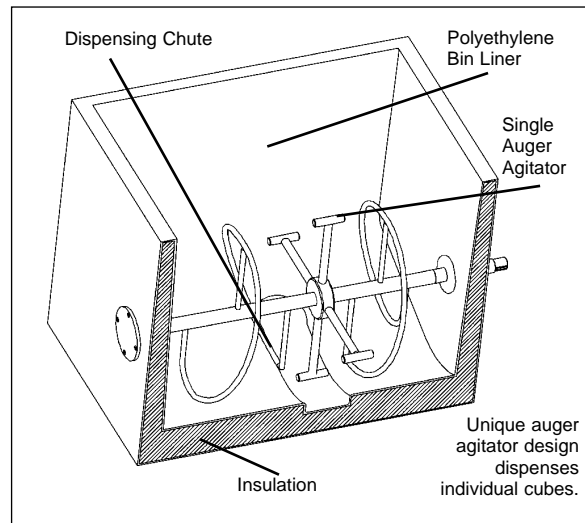
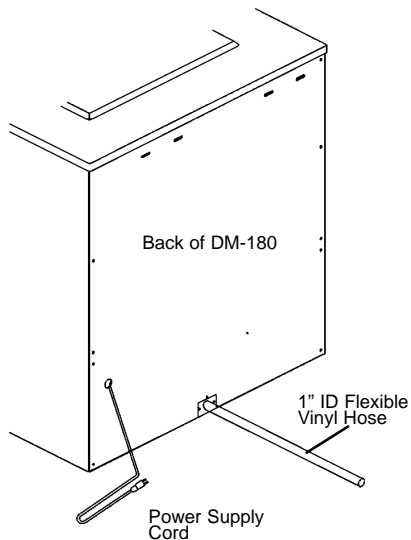
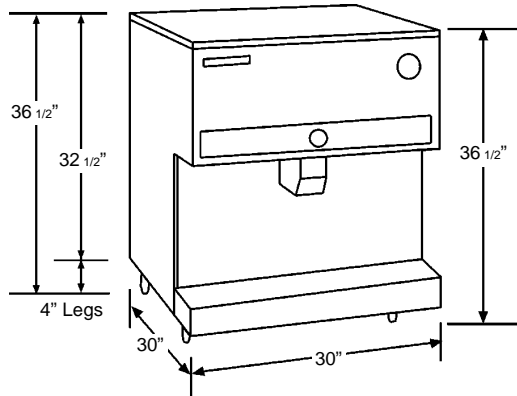
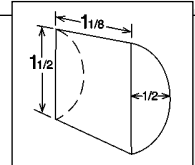

We reserve the right to change specifications without notice.

© **HOSHIZAKI AMERICA, INC.**

618 Hwy. 74 S., Peachtree City, GA 30269

1-800-438-6087

FAX 1-800-345-1325

TEL 770-487-2331

www.hoshizaki.com

Printed in U.S.A.