

MagiKitch'n®

CM-RMB-600 / CM-SMB-600 Counter Model Radiant or Ceramic Coal Gas Charbroiler



OPTIONS AND ACCESSORIES (AT ADDITIONAL CHARGE)

- **Conversion Kits**
 - Ceramic coal option for CM-RMB-600
 - Radiant option for CM-SMB-600
- **MagiKrome Top Grids**
 - Standard Spacing
 - Fish Spacing
- **Scround Rods Top Grids**
 - Standard Spacing
 - Fish Spacing
- **Extra Deep Service Shelf**
 - 8" (203.2 mm)
 - 10" (254 mm)
 - 12" (304.8 mm)
- Lower Rack
- Round Rods Top Grid with Fish Spacing
- Fajita Top Grid
- Smoker Boxes
- Pan Cut Outs in Service Shelf
- Safety Pilot
- Flexible Hose and Disconnect Fittings
- Cutting Board
- MagiGriddle
- Back Shelf
- Top Grid Scraper
- Slip on Covers
- Side and Back Extensions
- Equipment Stand

Project _____

Item number _____

Quantity _____

CM-RMB-600 / CM-SMB-600

EXTERIOR CONSTRUCTION

- Double-walled outer cabinet
- Fully insulated
- Stainless steel sides, front, back and bottom
- Top Grid - 1/2" (12.7 mm) cold-rolled steel rods

INTERIOR CONSTRUCTION

- 95% stainless steel
- All stainless steel burners and radiant burner covers

OPERATION

- Free floating top grid allows for expansion and contraction without warping
- E-Z Tilt top grid drains 70% of grease into front trough
- **CM-RMB-600** - Stainless steel V-shaped radiant for each burner
- **CM-SMB-600** - Ceramic coal screen
- Front mounted individual burner controls
 - 4 burners (CM-RMB/SMB 624)
 - 6 burners (CM-RMB/SMB 630)
 - 7 burners (CM-RMB/SMB 636)
 - 10 burners (CM-RMB/SMB 648)
 - 13 burners (CM-RMB/SMB 660)
 - 16 burners (CM-RMB/SMB 672)

STANDARD FEATURES

- Convertible design allows operator to quickly change from radiant to coal style cooking with use of an optional conversion kit.
- Runner tube pilot system
- Round rods top grid with standard spacing
- Water tubs
- 6" (152.4 mm) stainless steel front service shelf
- Utility bar for quick access cooking utensil storage
- Removable grease box
- Cleaning brush
- One year limited parts and labor warranty

APPROVALS

- CSA Certified (AGA, CGA)
- NSF Listed
- MEA Approved
- CE Certified



Patent Pending

MagiKitch'n Equipment Corp., P.O. Box 501, Concord, NH 03302-0501 • 509 Route 3A, Bow NH 03304, USA
Phone (603) 225-6684 • Fax (603) 225-8472 • www.magikitchn.com



L10-135 Rev 1 (08/03)



CM-RMB-600 / CM-SMB-600 Counter Model Radiant or Ceramic Coal Gas Charbroiler

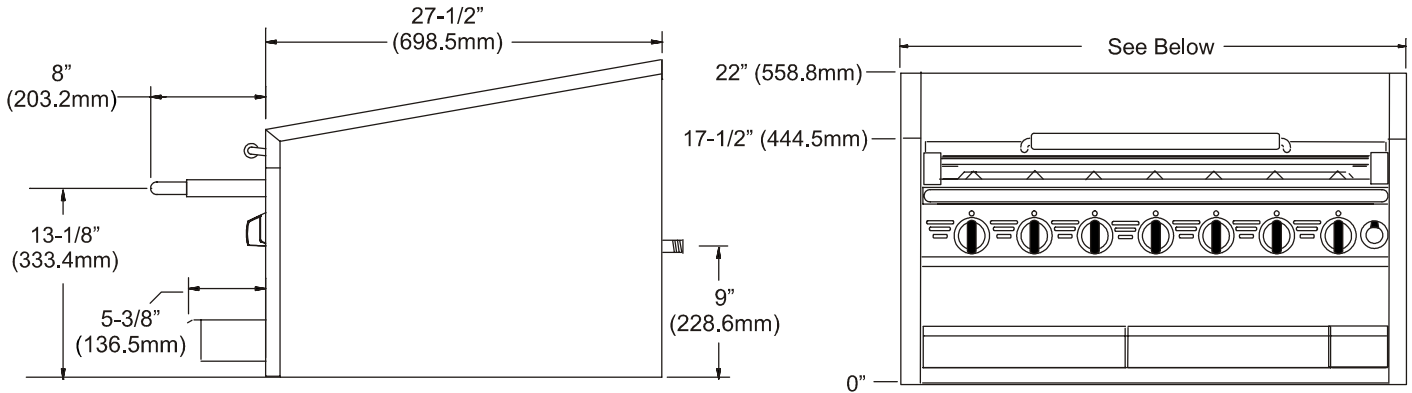

GAS REQUIREMENTS

Gas Type	Burner Manifold Pressure	Model	Gas Input per Hour (Per Burner) 15,000 / 20,000
Natural Gas	4" W.C. / 10 mbars / 1kPa	CM-RMB/SMB 624	60,000 BTUs / 80,000 BTUs
L.P. Gas	10" W.C. / 25 mbars / 2.5 kPa	CM-RMB/SMB 630	90,000 BTUs / 120,000 BTUs
3/4" NPT		CM-RMB/SMB 636	105,000 BTUs / 140,000 BTUs
		CM-RMB/SMB 648	150,000 BTUs / 200,000 BTUs
		CM-RMB/SMB 660	195,000 BTUs / 260,000 BTUs
		CM-RMB/SMB 672	240,000 BTUs / 320,000 BTUs

DIMENSIONS

Model	Counter Space	Cooking Area	Top Grid
CM-RMB/SMB 624	24" W x 35 1/2" D (60.9 x 90.1 cm)	513 sq.in. (3,314 cm ²)	One 20 3/4" W x 24 3/4" D (52.7 x 62.9 cm) grid
CM-RMB/SMB 630	30" W x 35 1/2" D (76.2 x 90.1 cm)	662 sq.in. (4,271 cm ²)	One 26 3/4" W x 24 3/4" D (67.9 x 62.9 cm) grid
CM-RMB/SMB 636	36" W x 35 1/2" D (91.4 x 90.1 cm)	810 sq.in. (5,233 cm ²)	One 32 3/4" W x 24 3/4" D (83.2 x 62.9 cm) grid
CM-RMB/SMB 648	48" W x 35 1/2" D (121.9 x 90.1 cm)	1107 sq.in. (7,145 cm ²)	Two 22 3/8" W x 24 3/4" D (56.8 x 62.9 cm) grids
CM-RMB/SMB 660	60" W x 35 1/2" D (152.4 x 90.1 cm)	1404 sq.in. (9,063 cm ²)	One 20 3/4" W x 24 3/4" D (52.7 x 62.9 cm) grid Two 18" W x 24 3/4" D (45.7 x 62.9 cm) grids
CM-RMB/SMB 672	72" W x 35 1/2" D (182.8 x 90.1 cm)	1704 sq.in. (11,001 cm ²)	One 24 1/8" W x 24 3/4" D (61.3 x 62.9 cm) grid Two 22 3/8" W x 24 3/4" D (56.8 x 62.9 cm) grids

Working height for all models is 17 1/2" (44.4 cm)

SHIPPING INFORMATION

Model	Approx. Weight - Crated	Approx. Weight - Uncrated	Crate Sizes
CM-RMB/SMB 624	210 lbs. (95.2 kg)	175 lbs. (79.4 kg)	31" x 34" x 40" (78.7 x 86.4 x 101.6 cm)
CM-RMB/SMB 630	280 lbs. (127 kg)	245 lbs. (111 kg)	37" x 34" x 40" (94.0 x 86.4 x 101.6 cm)
CM-RMB/SMB 636	350 lbs. (158.7 kg)	315 lbs. (142.9 kg)	43" x 34" x 40" (109.2 x 86.4 x 101.6 cm)
CM-RMB/SMB 648	425 lbs. (192.7 kg)	390 lbs. (176.9 kg)	55" x 34" x 40" (139.7 x 86.4 x 101.6 cm)
CM-RMB/SMB 660	565 lbs. (256.3 kg)	490 lbs. (222.3 kg)	67" x 34" x 40" (170.2 x 86.4 x 101.6 cm)
CM-RMB/SMB 672	705 lbs. (318.7 kg)	630 lbs. (285.7 kg)	79" x 34" x 40" (200.6 x 86.4 x 101.6 cm)

SHORT FORM SPECIFICATION

Provide MagiKitch'n counter model radiant or ceramic coal charbroiler. Unit shall be gas heated and shall cook by means of gas burners. Charbroiler shall be single unit. Unit shall be double-walled stainless steel construction, and fully insulated on all sides. Provide with independent gas burners. Individual burner controls shall be mounted every 4 to 4 1/2 inches for flexible use. Convertible design allows operator to quickly change from radiant to coal style cooking with an optional conversion kit. Provide options and accessories as indicated.