



# MKG Gas Griddle

24", 36", 48", 60" and 72"

Project \_\_\_\_\_

Item number \_\_\_\_\_

Quantity \_\_\_\_\_



### EXTERIOR CONSTRUCTION

- Heavy 1" thick griddle plate
- Double-walled and reinforced stainless steel cabinet
- No exposed fasteners allowing easy cleanup

### INTERIOR CONSTRUCTION

- 95% stainless steel
- All stainless steel burners

### OPERATION

- Snap Action thermostat maintains temperature between 200°F and 450°F with +/-15°F accuracy, combined with a piezo ignitor for easy push button ignition
- Optional Electric thermostat maintains temperature between 200°F and 550°F with +/-10°F accuracy. This upgraded control includes matchless ignition which automatically lights the pilot when the power is turned on
- Optional Solid State thermostat maintains temperature between 150°F and 550°F with a +/-5°F accuracy. As with the Electric thermostat, matchless ignition is included
- Easy cleanup with an Extra Large 2.8 gallon grease container (2 provided on 72" models) as well as no exposed exterior fasteners for quick, easy equipment wipe-down

### STANDARD ACCESSORIES

- Snap action t-stat with piezo ignitor
- 15,000 BTU.hr burner for every 6", thermostatically controlled every 12".
- Front grease trough
- Large 2.8 gallon grease container (two on 72" model)
- 4" legs (can be removed for flush mounting)

### OPTIONS AND ACCESSORIES

(AT ADDITIONAL CHARGE)

- Electric t-stat with matchless ignition system
- Solid state t-stat with matchless ignition system
- Chrome griddle plate (chrome kit includes scraper, palmetto brush, spatula and MagiKitch'n griddle cleaner)
- Service Shelf available in 8", 10" or 12" depth.
- Pan cutouts for 1/6 - 1/9 pan on 10" or 12" service shelves
- Towel bar with or without service shelf
- Cutting board for 10" or 12" service shelves (specify length)
- NSF approved, stainless steel griddle stand
- Flue diverter

### OPTIONS

- Electric thermostat maintains temperature between 200°F and 550°F with +/-10°F accuracy. This upgraded control includes matchless ignition which automatically lights the pilot when the power is turned on
- Solid State thermostat maintains temperature between 150°F and 550°F with a +/-5°F accuracy. As with the Electric thermostat, matchless ignition is included

### APPROVALS

- CSA Certified (AGA, CGA)
- NSF Listed



Patent Pending



# MKG Gas Griddle 24", 36", 48", 60" and 72"

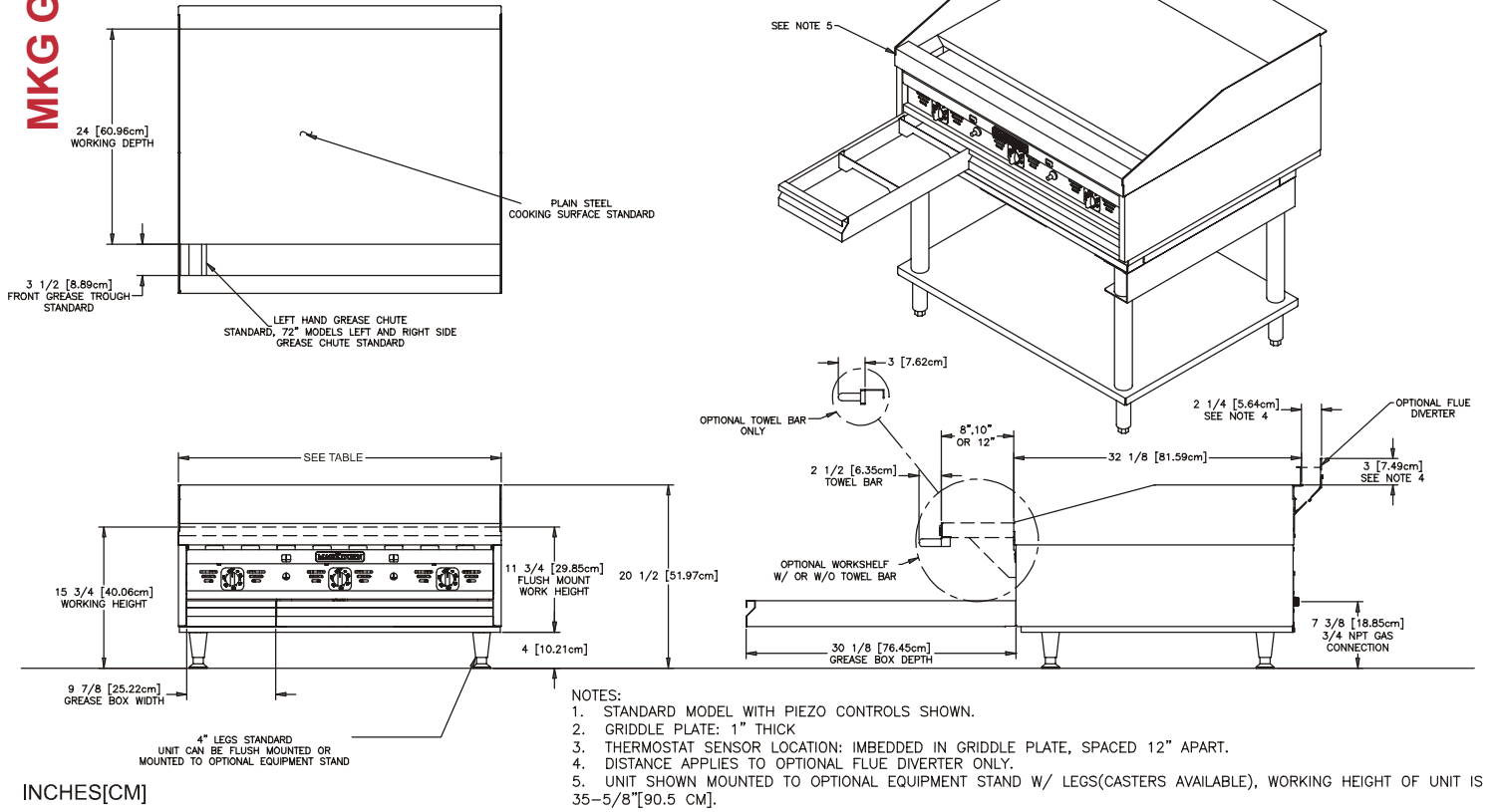

## GAS REQUIREMENTS

|  |                      |               |               |                |                |                |
|--|----------------------|---------------|---------------|----------------|----------------|----------------|
| 3/4" NPT Natural Gas 4.5" W.C. / 11 mbars / 1.1 kPa<br>Propane 10" W.C. / 25 mbars / 2.5 kPa | <b>SIZE</b><br>BTU's | 24"<br>60,000 | 36"<br>90,000 | 48"<br>120,000 | 60"<br>150,000 | 72"<br>180,000 |
|--|----------------------|---------------|---------------|----------------|----------------|----------------|

## ELECTRICAL

| CONTROL TYPE | AMPS AT 115V |     |     |     |     |
|--------------|--------------|-----|-----|-----|-----|
|              | 24"          | 36" | 48" | 60" | 72" |
| SNAP ACTION  | N/A          | N/A | N/A | N/A | N/A |
| ELECTRIC     | 0.4          | 0.6 | 0.8 | 1.0 | 1.2 |
| SOLID STATE  | 0.5          | 0.7 | 0.9 | 1.1 | 1.3 |

## DIMENSIONS

| MODEL        | OVERALL HEIGHT* | WORKING HEIGHT* | OVERALL DEPTH  | OVERALL WIDTH | GREASE BOX GALLONS [LITERS] | NUMBER OF CONTROLS | SHIPPING WEIGHT LBS [KG](crated) |
|--------------|-----------------|-----------------|----------------|---------------|-----------------------------|--------------------|----------------------------------|
| <b>MKG24</b> | 20.5 [51.97]    | 15.75 [40.06]   | 32.125 [81.59] | 24 [60.96]    | 2.84 [10.75]                | 2                  | 309 [140.45]                     |
| <b>MKG36</b> | 20.5 [51.97]    | 15.75 [40.06]   | 32.125 [81.59] | 36 [91.44]    |                             | 3                  | 465 [211.36]                     |
| <b>MKG48</b> | 20.5 [51.97]    | 15.75 [40.06]   | 32.125 [81.59] | 48 [121.92]   | 5.68 [21.50]                | 4                  | 615 [279.55]                     |
| <b>MKG60</b> | 20.5 [51.97]    | 15.75 [40.06]   | 32.125 [81.59] | 60 [152.40]   |                             | 5                  | 775 [352.27]                     |
| <b>MKG72</b> | 20.5 [51.97]    | 15.75 [40.06]   | 32.125 [81.59] | 72 [182.88]   |                             | 6                  | 855 [388.64]                     |

\*Overall height and working height include 4" removable legs. Unit can be flush mounted

## SHORT FORM SPECIFICATIONS

Provide MagiKitch'n gas fired griddle. Unit shall be gas heated and shall cook by means of gas burners. Griddle shall be single unit and may be supported by legs. Unit shall be double-walled stainless steel construction, and fully insulated on all sides. Provide with independent gas burners. Individual thermostats shall be mounted every 12 inches for flexible use and temperature accuracy. Provide options and accessories as indicated.

