



# Model PPG-14DL(LL), PG14D, and RS14D Gas Pasta Units

Model PPG-14DL(LL), PG14D, and RS14D Gas Pasta Units

Project \_\_\_\_\_

Item No. \_\_\_\_\_

Quantity \_\_\_\_\_



(PPG-14DL shown with optional casters)

## STANDARD SPECIFICATIONS

### CONSTRUCTION

- Self-contained work center for pasta preparation.
- Separate rinsing/hold tanks, equipped with drain and overflow.
- Stainless steel cabinet.
- Stainless steel (type 316, marine grade) tank construction for the cooker and rinse station.
- Cooking rack to accommodate smaller baskets.
- Quick opening 1-1/4" drain valve in each tank.
- Tank design features a self skimming, 1" overflow drain in each tank.

### CONTROLS

- Digital thermostat and time display.
- Solid state cooking controls integrated into the digital control unit.
- Programmable simmer temperature.
- **Two year warranty on controller!**

### OPERATIONS

- Cooking/warming section holds 12 gallons (45.4 liters) of water.
- Automatic temperature control.
- Basket lift automatically lowers pasta into water at start of cook/warm cycle.
- Basket lift automatically raises pasta when the cook/warm cycle is complete.
- Easy pasta rinsing is assured in the rinse/hold tank using the swing away faucet.

### APPROVALS

- CSA Certified (AGA, CGA)
- NSF Listed
- MEA Approved



OPTIONS AND ACCESSORIES	PPG14D		PG14D	RS14D
	L	LL		
Automatic single basket lift (L)	std	----	opt	----
Automatic dual basket lift (LL)	----	std	opt	----
Digital thermostat & controls	std	std	std	----
Single drain attachment	std	std	opt	----
Swing-away hot and cold faucet	std	std	----	opt
Front mounted water fill/compensator	opt	opt	opt	----
Insulation for rinse tank	opt	opt	----	opt
Casters	opt	opt	opt	opt
Basket rack	std	std	std	opt
Large bulk pasta basket 13" x 16-1/4" x 10"	opt	opt	opt	----
Small bulk pasta basket 13" x 13" x 8-1/2"	opt	opt	opt	----
Round pasta basket (6) 4-7/8" dia x 7"	opt	opt	opt	----
Dual oblong basket (2) 6-1/2" x 17 x 7"	opt	opt	opt	----

std = Standard Accessories  
opt = Optional Accessories  
---- = Not Available For This Model

Patent Pending



## Model PPG-14DL(LL), PG14D, and RS14D Gas Pasta Units

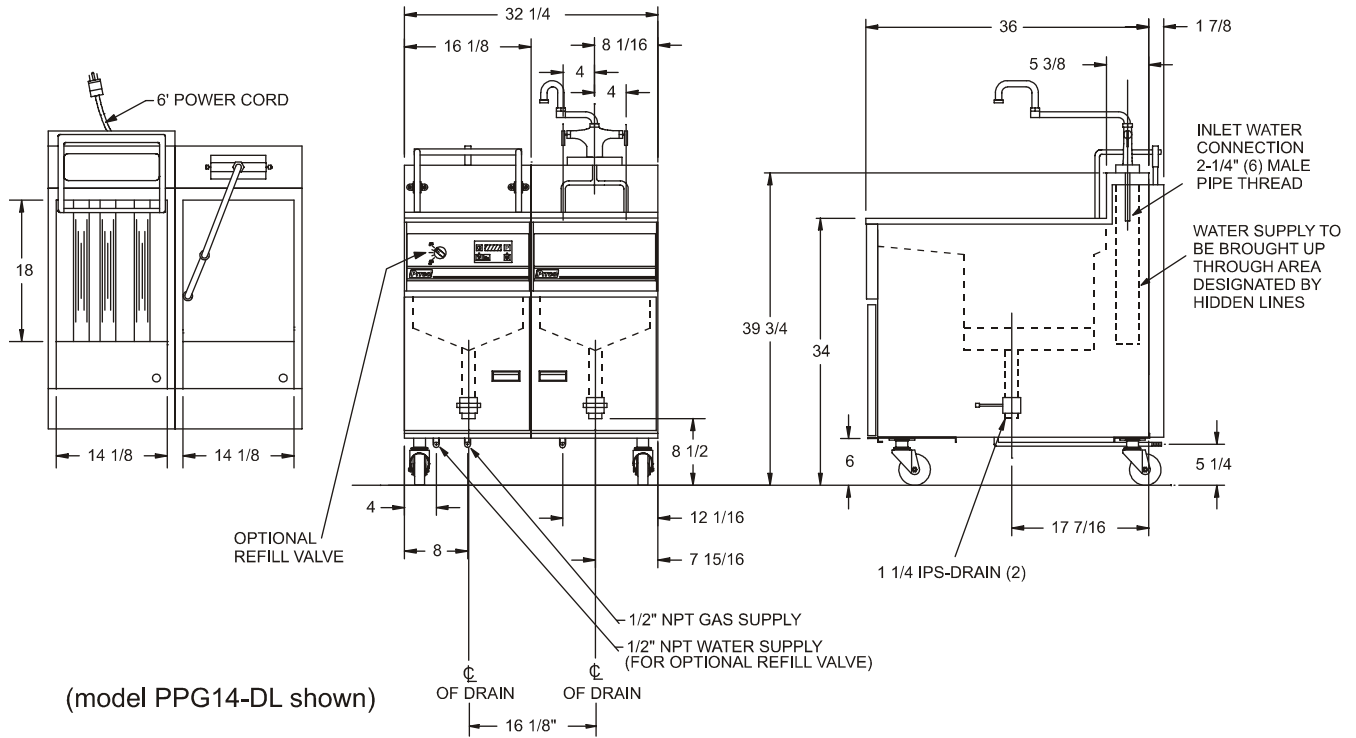

Many different combinations are available. Call your dealer/distributor for more details.

ELECTRICAL			WATER CAPACITY
Option	Voltage/Phase/Hz		12 gallons (45.4 liters)
	120 / 1 / 60	240 / 1 / 50	<b>SHIPPING INFORMATION</b>
	Amps/EA	Amps/EA	335 pounds (151.9 Kg)
With Basket Lift(s)	3.0	1.5	<b>SHIPPING CARTON</b>
Without Basket Lift(s)	1.0	.05	55 cu. ft. / 1.56 cu. meters
PERFORMANCE CHARACTERISTICS			GAS CONSUMPTION
Performance varies depending upon type of pasta and baskets used.			77,500 BTU's / Hour (19,530 Kcal) Available in Natural or Propane gas. For other fuel types, contact your Dealer/Distributor.
SHORT FORM SPECIFICATION			
Provide Pitco Model PPG14DL(LL), PG14D or RS14D Pasta Units. Cooker unit shall have the ability to boil water and maintain a thermostatically-controlled simmer. Cooker shall have a digital thermostat with integrated cooking controls. Cooking tank shall be constructed of type 316 stainless steel and hold 12 gallons (45.4 liters) of water with a bottom 1 1/4" drain and a self-skimming 1" overflow drain. Entire cabinet shall be construction of stainless steel. Provide accessories as follows.			
TYPICAL APPLIACTION			
Typical Application – Cooking of pasta from raw to done. Re-constituting pasta to serving readiness. Rethermalizing of pre-cooked foods.			

