



Series 2000

Reach-In Freezers

ITEM # QTY.

PROJECT

DATE

Single Door Reach-In Freezer



Model 2010F

Randell Series 2000 Reach-Ins are built for years of efficient, high performance service. The top mounted, expansion valve refrigeration system offers the highest, most consistent performance available while maximizing usable interior space.

FINISHES:

- Standard Series Doors/Louver:** Stainless steel.
Exterior Sides: Anodized aluminum. **Interior:** Anodized aluminum
- E Series** Cabinet interior, exterior sides, fronts, and doors stainless steel.



■ Model 2010F - Solid Door ■ Model 2011F - Glass Door

STANDARD FEATURES:

- Expansion Valve
- Pressure Control
- Top mounted Compressor & Evaporator Coil
- C.F.C. Free R-404a Refrigerant
- Efficient Hot Gas Condensate Evaporator
- Full Automatic Coil Defrost With Programmable Timer and Safety Switches
- 9' Cord & Plug
- Main Power Supply Switch
- Exterior Thermometer
- Self-Closing Cam Lift Hinges with 120° Open Feature (Lifetime Warranty)
- Automatic Interior Light
- 6" Casters - Factory Mounted (Front two Locking)
- Cylinder Door Locks
- Polyurethane Insulation
- Snap-In Magnetic Door Gaskets
- Condensate Heaters Around All Door Openings
- 3 Baked Epoxy Coated Wire Shelves With Stainless Steel Support Clips (Adjustable every 1")
- Fully Coved Interior Meeting N.S.F. Standard #7

SPECIFICATIONS:

CABINET EXTERIOR: Cabinet body is constructed of all metal, inside & out. The top, bottom, & back are galvanized steel. Front and sides are available in finishes as listed above. Door and louver are stainless steel and are removable without tools. Unit on 6" casters, front two are locking.

CABINET INTERIOR: Interior of cabinet is fully coved to meet N.S.F. standard #7. The interior walls, ceiling and door liner are available in either stainless steel or anodized aluminum as listed above. Foamed in place, CFC free urethane insulation. Snap-in A.B.S. breaker strips allow access to condensate heater wires.

DOORS: Stainless steel front with either anodized aluminum or stainless steel liner, mounted on heavy duty cam lift hinges with concealed automatic light switch, heavy duty chrome handle, cylinder door lock. Glass Doors to be insulated glass with bright extruded aluminum frames, switch for interior light mounted on exterior of glass door unit.

REFRIGERATION: Top mounted condensing unit and evaporator coil, expansion valve system with pressure control, factory tested and balanced to maintain (0° F. to -5° F.) average interior temperature utilizing CFC free 404a refrigerant. Evaporator coil is coated to resist corrosion. Unit supplied with master on/off switch and 9' cord and plug. Access to service points without tools is standard. Provided with full automatic coil defrost with programmable timer and safety switches.

Randell Manufacturing, Inc.

520 S. Coldwater Rd. Weidman, MI 48893
Phone 1-800-621-8560 Fax 1-800-634-5369 www.randell.com

For the most current specifications, visit our WebSite. www.randell.com

Printed/Revised: May, 2002
Rancraft Section 2, Page 2

Dimensional Data

Series 2000

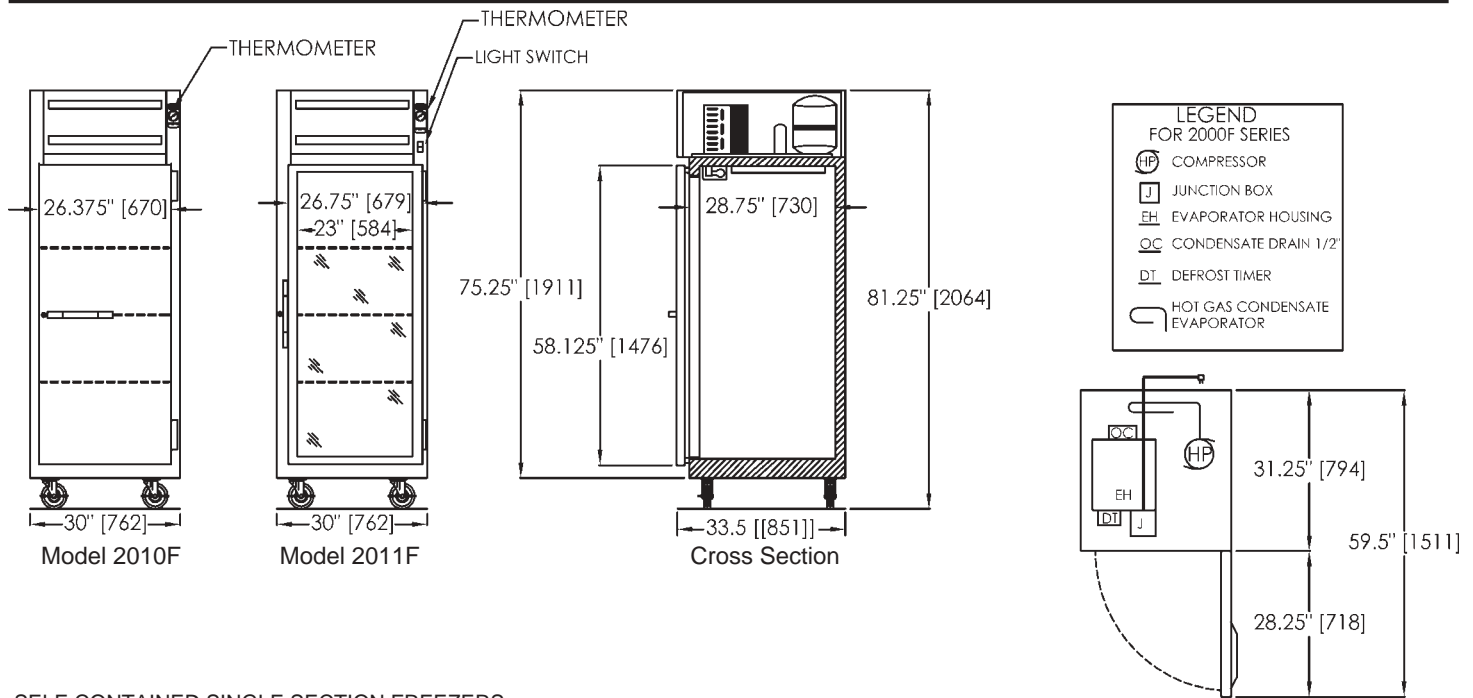

SELF-CONTAINED SINGLE SECTION FREEZERS

Model No.	L	D	H	Doors	Cu./Ft.	Shelves	Shelves Sq. Ft.	H.P.	BTU/Hr.	Volt	Amp.	NEMA	Shipping Wt.
2010F solid door	30"	33 1/2"	81 1/4"	1	24	3	11.75	1/2	2180*	115/60/1	9.3	5-15P	425
2011F glass door	30"	33 1/2"	81 1/4"	1	24	3	11.75	1/2	2180*	115/60/1	9.3	5-15P	425

* Based on 90° ambient and -10° evaporator.

FOR REMOTE MODELS

Use same specifications as self-contained models except for:

Model No.	Rec. H.P.	Rec. BTU/Hr.	Amp.	Ship Wt.
2010FR solid door	1/2	2180	7	345
2011FR glass door	1/2	2180	7	345

Note: All remote reach-ins come standard on 6" legs in lieu of casters.

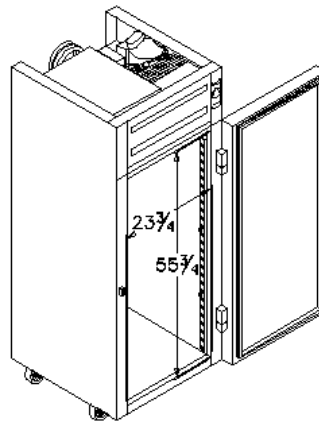

Door Opening Dimensions

Some models available for -10°F applications. Consult factory.



Our Product Line Is On



AutoCAD™ R12-2000
AutoCAD™ Lt

TRAYSLIDE CAPACITIES

Universal Pan Slides Model....UNIVPS - set of two.

For 12 x 20 food pans or 18 x 26 sheet pans.

Maximum capacity of 12" x 20" food pans per full height section:
(6) 6" deep pans, (8) 4" deep pans, (18) 2" deep pans.

Maximum capacity of 18" x 26" sheet pans with 2" spacing is (22).

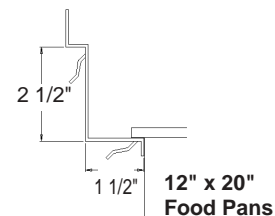
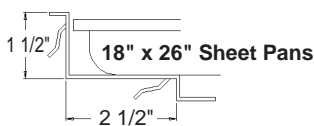

OPTIONS

- Universal Tray Slides (set of two) Qty. _____ Sets
- 1/2 Doors Solid Glass Qty. _____ Location _____
- 6" Legs
- Remote (Add Suffix "R")
- Extra Interior Shelves Qty. _____
(maximum of (23) or (20) additional on 1.5" centers-leaves 1" clear)
- Finished Back _____
- Export Voltage(s) Specify Voltage _____
- Prison Package

Randell Manufacturing, Inc.

Due to a continuous program of product improvement, Randell reserves the right to make changes in design and specifications without prior notice