



4030GA Series Display Merchandisers

ITEM # QTY.

PROJECT

DATE

Self-Contained Countertop Display Case



Model 4030GA

Self-contained counter-top display case with glass doors, top, and sides. Stainless steel interior and exterior. Randell bottom mounted refrigeration system with thermostatic control, system utilizes "CFC free", R-134a refrigerant. Foamed in place, "CFC free" insulation. (3) powder coated, angled display shelves and cordset for 120V plug-in operation.



Model 4030GA

STANDARD FEATURES:

- Self-contained, bottom mounted refrigeration system with thermostatic control, system utilizes "CFC free", R-134a refrigerant.
- Sliding glass doors in rear, with glass front, top, and sides.
- Stainless steel exterior and interior surfaces
- Foamed in place CFC free, urethane insulation.
- Condensate evaporator.
- Thermostatic control for easy temperature adjustment.
- Three powder coated, angled display shelves.

OPTIONAL:

- Laminate finish on base.
- Interior light.
- 4" high legs.

SPECIFICATIONS:

CABINET EXTERIOR: Cabinet body to have all stainless steel surfaces with self-closing insulated glass sliding doors at rear. Unit with solid glass top, front, and sides. Louver panel to be die-formed stainless steel, allowing ventilation of condensing unit.

CABINET INTERIOR: Interior to be all stainless steel with three, angled, powder coat finished shelves provided. Interior light is optional. Unit insulated with CFC free, foamed in place urethane insulation.

DOORS: Door to be insulated glass, nylon framed, and are easily removed for cleaning or restocking.

REFRIGERATION: CFC free, R-134a bottom mounted refrigeration system with condensing unit, evaporator blower coil, automatic condensate evaporator, and thermostatic control for operator adjustability. Unit totally prewired and to be supplied with 9' cordset (NEMA 5-15P) for 120V plug-in operation.

Randell Manufacturing, Inc.

520 S. Coldwater Rd. Weidman, MI 48893
Phone 1-800-621-8560 Fax 1-800-634-5369

For the most current specifications, visit our WebSite. www.randell.com

Printed/Revised: *January, 2003*
Rancraft Section 6, Page 5

www.randell.com

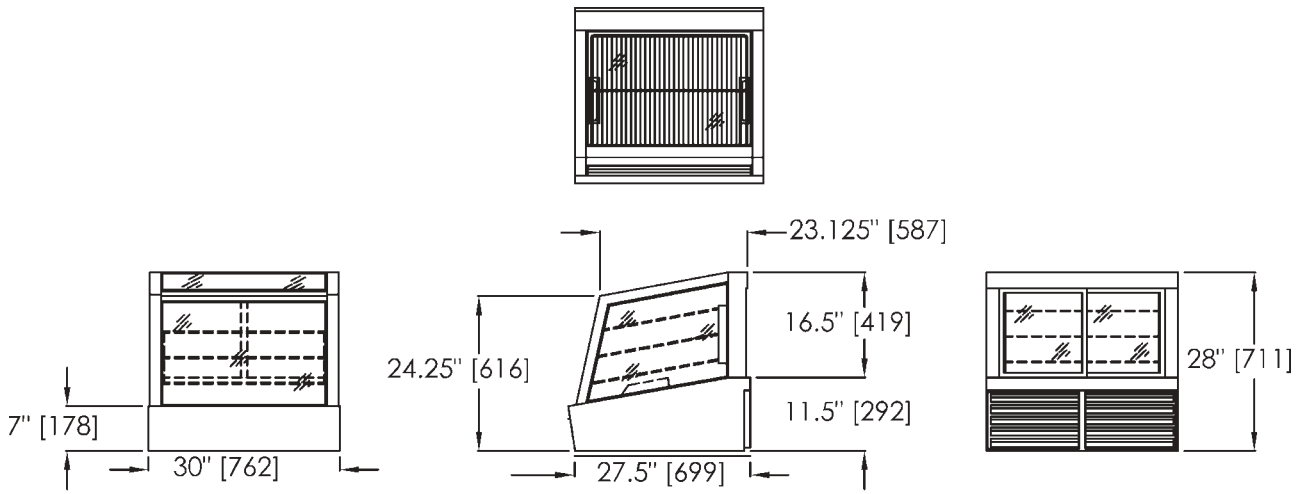

LEGEND FOR MODEL # 4030GA

AFF. = ABOVE FINISHED FLOOR

COMPRESSOR

JUNCTION BOX

HOT GAS CONDENSATE EVAPORATOR

CONDENSATE DRAIN 1/2" PVC 10" AFF.

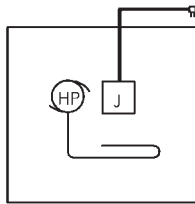

Door Opening Sizes - Interior Depths

Unit Length	Clearances Through Door		Interior Depth Behind Sliding Glass Doors
	Lt. to Rt.	Top to Bottom	
30"	9 1/2"	13 1/2"	23" max. 21" min.

Model	L	D	H	Style	No. of Shelves	Storage Cu. Ft.	H.P.	Volt	Amp.	NEMA	Ship Wt.
4030GA	30"	27.5"	28"	Counter top	3	5.3	1/4	115/60/1	7.1	5-15P	240

Our Product Line Is On



AutoCAD™ R12-2000
AutoCAD™ Lt



Randell Manufacturing, Inc.

Due to a continuous program of product improvement, Randell reserves the right to make changes in design and specifications without prior notice