

HDO-12, HDO-24, HDO-36  
Step-up Models: HDO-24SU, HDO-36SU

#### Standard Features

- Available in 12", 24", and 36" (24" and 36" step-up units also available)
- 26,000 BTU open top non-clogging burner
- Hi/Low burner controls
- Stainless steel front and sides
- 3/4" rear gas connection and pressure regulator
- Full width crumb tray
- 12" cast flush top grates
- 4" stainless steel legs
- One year Parts and Labor Warranty



(Model HDO-24)

#### STANDARD CONSTRUCTION SPECIFICATIONS

**Exterior Finish:** Stainless steel front and sides. Rear and bottom panels are constructed of aluminized steel.

**Range Top:** Each burner is a 26,000 BTU cast iron non-clogging burner (available in step-up). Removable flush top grates. Center-to-center measurements between burners not less than 12", side-to-side or front-to-back. Removable one piece, full width crumb tray provided under burners.

**Gas Heat Control System:** Each burner is controlled by a gas valve for independent control of flame. One standing pilot services each burner. A 3/4" rear gas connection is standard.

**Legs:** Stainless steel 4" adjustable legs.



Models:  HDO-12     HDO-24     HDO-36     HDO-24SU     HDO-36SU

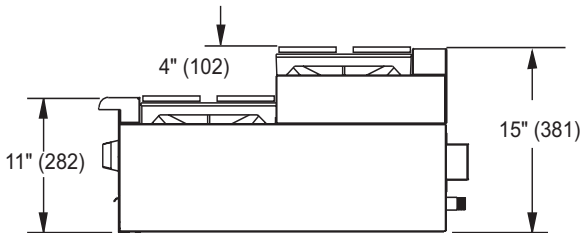
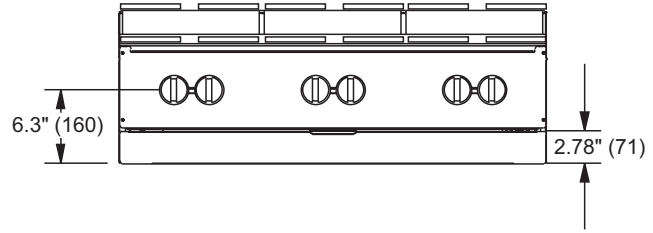
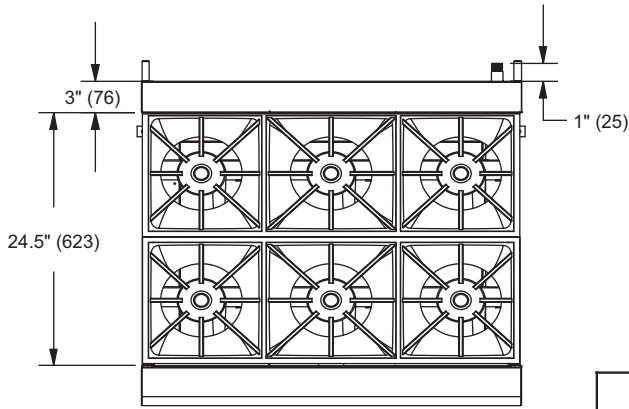

**DIMENSIONS & WEIGHT**

Model	Width	Burners BTU each	Crated Width	Crated Depth	Crated Weight
HDO-12	12.25" (305)	2@ 26,000	31" (787)	39" (991)	155lbs (70.4 kg)
HDO-24	24.5" (610)	4@ 26,000	31" (787)	39" (991)	190 lbs (86.3 kg)
HDO-36	36.625" (916)	6@ 26,000	55" (1398)	39" (991)	230 lbs (105 kg)
HDO-24SU	24.5" (914)	4@ 26,000	31" (787)	39" (991)	190 lbs (86.3 kg)
HDO-36SU	36.625" (916)	6@ 26,000	55" (1398)	39" (991)	230 lbs (105 kg)

**UTILITY INFORMATION**

**GAS:** Each unit has a 3/4" rear gas connection with a male NPT connector. Minimum supply pressure is 4" W.C. for natural gas and 10" W.C. for propane. All units require a regulated gas supply; pressure regulator to be ordered separately. If using a flexible hose gas connection, the I.D. of the hose must not be smaller than the connector on the unit and must comply with ANSI Z21.69, providing an adequate means of restraint to prevent undue strain on the gas connection.

Model	GAS	
	Natural BTU/Hour	Propane BTU/Hour
HDO-12	54,000	40,000
HDO-24	104,000	80,000
HDO-36	156,000	120,000
HDO-24SU	104,000	80,000
HDO-36	156,000	120,000

**MISCELLANEOUS**

- If casters are used with flex hose, a restraining device should be used to eliminate undue strain on the flex hose.
- Minimum clearance from noncombustible construction is zero. Minimum clearance from combustible construction is 10" on sides and 6" on rear.
- Install under vented hood.
- Check local codes for fire and sanitary regulations.

**NOTICE:**

Southbend has a policy of continuous product research and improvement. We reserve the right to change specifications and product design without notice. Such revisions do not entitle the buyer to corresponding changes, improvements, additions or replacements for previously purchased equipment.

**OPTIONS AND ACCESSORIES**

- Stainless Steel Stand
- High Performance WOK Ring
- 2" high insulator base for mounting on refrigerated base

**INTENDED FOR COMMERCIAL USE ONLY.  
NOT FOR HOUSEHOLD USE.**



1100 Old Honeycutt Rd., Fuquay-Varina, NC 27526  
www.southbendnc.com