



Countertop Conveyor Oven TCO2114



Heating

There are upper and lower independent, pre-formed tubular heaters that radiate the heat throughout the cooking chamber. Heaters are controlled by electronic thermostats. The allowable temperature range is 200°F - 599°F (93°C - 315°C), and the cook time range is 30 seconds to 15 minutes.

Electrical

The oven is wired 208V or 240V, 60 Hz, 1-phase; or 230V, 50 Hz, 1-phase; or 380-400V, 50 Hz, 3-phase. See electrical information chart on back. The oven is rated at 5.0kW on 208V, 230V and 380-400; oven is rated 5.3kW when used on 240V. 208V and 240V ovens are equipped with an attached 6-ft electrical cord and 6-30P NEMA plug; 230V oven is equipped with 1.8 m cord & IEC 309 plug; 380-400V ovens require field wiring.

New conveyor oven with precision electronics.

- High production with consistent quality
- Precise cook times and temperatures can be entered into patented MenuSelect® control
- Five (5) programmable menus, each has independent time and temperature selections.
- Electronically calibrated for accurately maintaining precise temperatures
- Top and bottom temperatures are individually controlled
- Safe, cool exterior

Application

Conveyor ovens are designed to easily and quickly cook, bake or broil with consistent quality results. Ideal for pizza, garlic toast, cookies, sandwiches, pretzels and much more.

General Information

The conveyor oven is designed for placement on a countertop and can be stacked up to 3 high with stacking brackets. The oven is equipped with a 14" wide, stainless steel chain-link belt. Selecting the direction from the mechanical switch can easily reverse the belt direction. The overall dimensions are 22"D x 42.5"W x 17.187"H, including legs, and the oven chamber is 22"W x 14.25"D x 3"H. The installed weight is 98 lbs. The oven is supplied with crumb trays, conveyor end trays and adjustable heat curtains.

Construction

The oven is constructed of welded and reinforced stainless steel. The outer case has a unique air-cooled "cool case", patented design, that is cool-to-the-touch.

MenuSelect® Control

The patented MenuSelect® control feature allows the operator to preset up to five (5) different times and temperatures into the control. The control accurately executes the times and temperatures automatically, and a ready light glows when the desired temperatures are reached.

Warranty

Warranted for one year covering parts and on-site labor under the "No Quibble" warranty (USA only).

Ordering Information

- 208V, 1-Phase, 50/60 Hz
- 230V, 1-Phase, 50/60 Hz (CE Version)
- 240V, 1-Phase, 50/60 Hz
- 380-400V, 3-Phase, 50 Hz (CE Version)

Accessories

- T2114Stack - Stacking Bracket

TCO 2114



6-30P NEMA Plug
208/240V, 50/60Hz

TCO 2114



IEC 309
230V, 50/60Hz



A MIDDLEBY COMPANY

1400 Toastmaster Drive
Elgin, Illinois 60120 USA
(847) 741-3300 Fax: (847) 741-0015
www.middleby.com



Toastmaster Countertop Conveyor Oven with Menu Select® TCO2114

We reserve the right to change specifications and product design without notice. Such revisions do not entitle the buyer to corresponding changes, improvements, additions, or replacements for previously purchased equipment.

Vertical stacking of Toastmaster Conveyor Oven ovens require the Conveyor Oven Stacking Kit (P/N T2112STACK)

- 2 ovens - 1 kit required
- 3 ovens - 2 kits required

Note: All figures in parentheses are in millimeters unless otherwise specified.

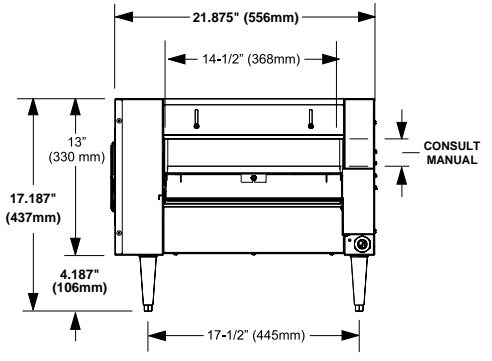
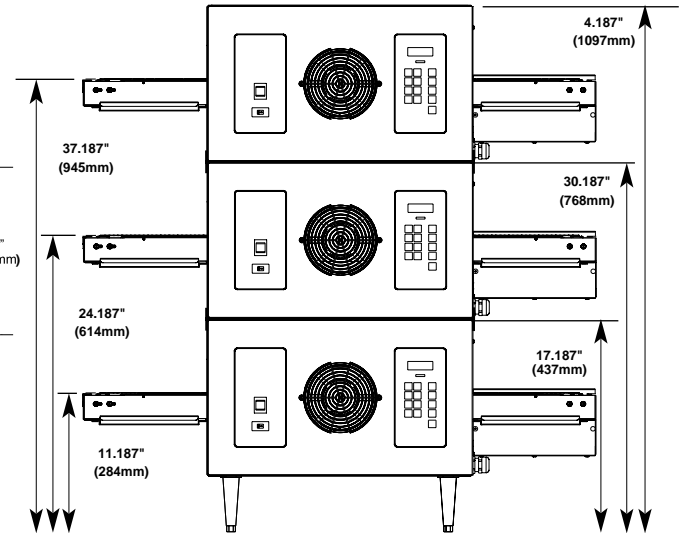
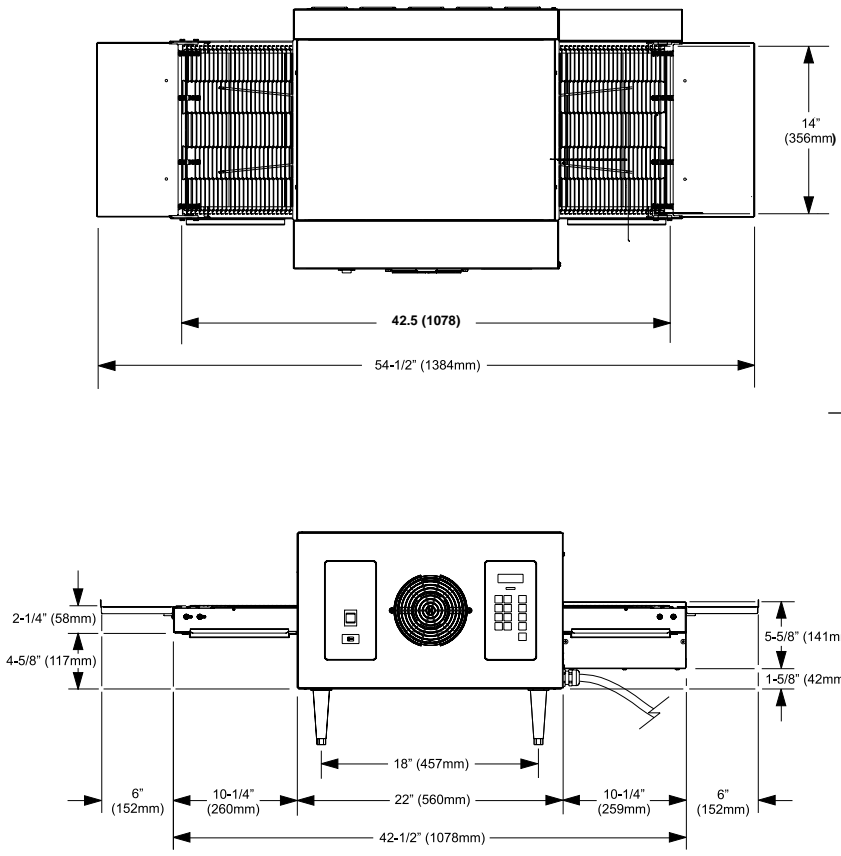

General Information

Model	Width	Height	Depth	Net Weight	Ship Weight
TCO2114	42.5" (1384)	17.187" (437)	21.875" (556)	98 lbs. 44.5 kg	112 lbs. (50.8 kg)

Electrical Information

Model#	Voltage	Phase	Connected					
			Hz	kW	L1	L2	L3	N
TCO21140063	208	1	60	5.0	24A	24A	--	--
TCO21140066	240	1	60	5.3	22A	22A	--	--
TCO21140035	230	1	50	5.0	21.1A	21.1A	--	--
TCO21140077	380-400	3	50	5.0	.3A	10.5A	10.3A	10.3A



1400 Toastmaster Drive, Elgin, IL 60120-9272 USA • (847) 741-3300 • Fax: (847) 741-0015
www.middleby.com