



# MODEL SHO-G Full-size Gas Convection Oven



SHO-G double stack gas oven shown with optional casters

Project \_\_\_\_\_  
Item No. \_\_\_\_\_  
Quantity \_\_\_\_\_

SHO-G

Baking compartment - accepts five 18" x 26" standard full-size baking pans in left-to-right position.  
All data is shown per oven section, unless otherwise indicated.

### EXTERIOR CONSTRUCTION

- Full angle iron frame
- Stainless steel front, top, sides and legs
- 19" (483mm) stainless steel legs for single ovens
- 6" (152mm) stainless steel legs for double stacked ovens
- Dependent stainless steel doors, dual pane thermal glass window on left hand door, solid right hand door
- Chrome-plated door handle
- Triple-mounted door hinge pins
- Removable front control panel
- Solid mineral fiber insulation on back, fiberglass insulation on top, sides and bottom

### INTERIOR CONSTRUCTION

- Fully covered, double-sided porcelainized baking compartment liner (14 gauge)
- Stainless steel combustion chamber
- Dual inlet blower wheel
- Five chrome-plated racks, eleven rack positions with a minimum of 1-5/8" (41mm) spacing

### OPERATION

- Direct fired gas system with inshot burners
- Electronic spark ignition control system
- Pressure regulator and manual gas service cut-off valve
- Thermostat with temperature control range of 200°F (93°C) to 500°F (260°C)
- Two speed fan motor
- 3/4 horsepower blower motor with automatic thermal overload protection

### STANDARD FEATURES

- Electro-mechanical thermostat
- 60 minute mechanical timer
- One year parts and labor oven warranty\*
- Three year limited oven door warranty\*

\* For all international markets, contact your local distributor.



### OPTIONS AND ACCESSORIES

(AT ADDITIONAL CHARGE)

- **Legs/casters:**
  - 6" (152mm) seismic legs
  - 6" (152mm) casters
  - 4" (107mm) low profile casters
- **Venting:**
  - Draft diverter
  - Draft hood
- **Gas hose with quick disconnect and restraining device:**
  - 48" (1219mm) hose
  - 36" (914mm) hose
- 25" (635mm) open stand with rack guide, stainless steel
- Base cabinet
- Extra oven racks
- Gas manifold (for double sections)
- Flue connector
- Extended warranty

### OPTIONS AND ACCESSORIES

(AT NO ADDITIONAL CHARGE)

- Single speed, 1/2 HP blower motor with automatic thermal overload protection

### BLODGETT OVEN COMPANY

www.blodgett.com

44 Lakeside Avenue, Burlington, VT 05401

Toll Free: (800) 331-5842 • Phone: (802) 860-3700 • Fax: (802) 864-0183



# MODEL SHO-G

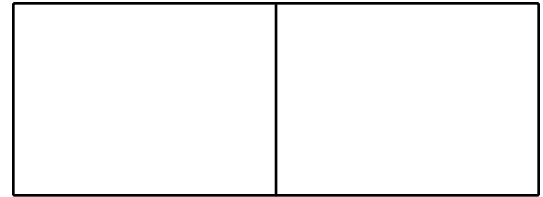

APPROVAL/STAMP

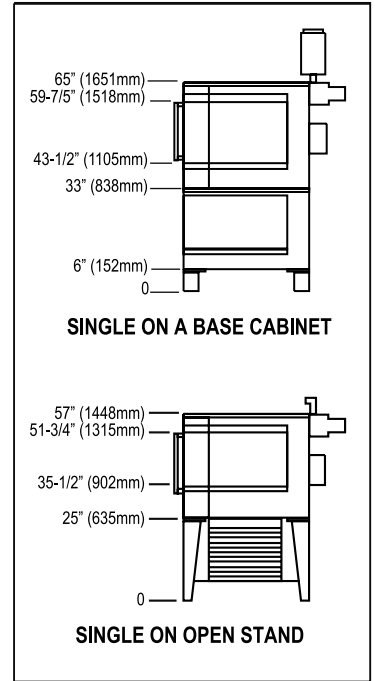
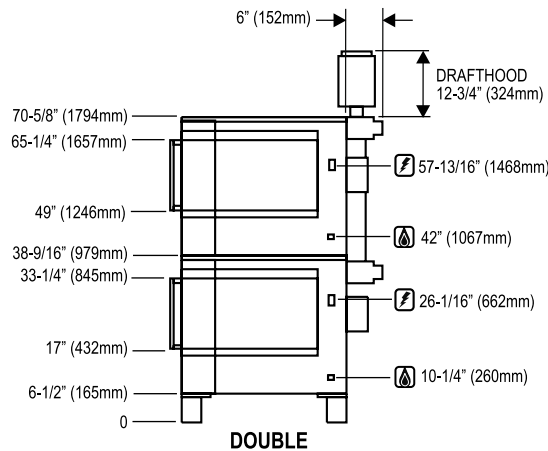
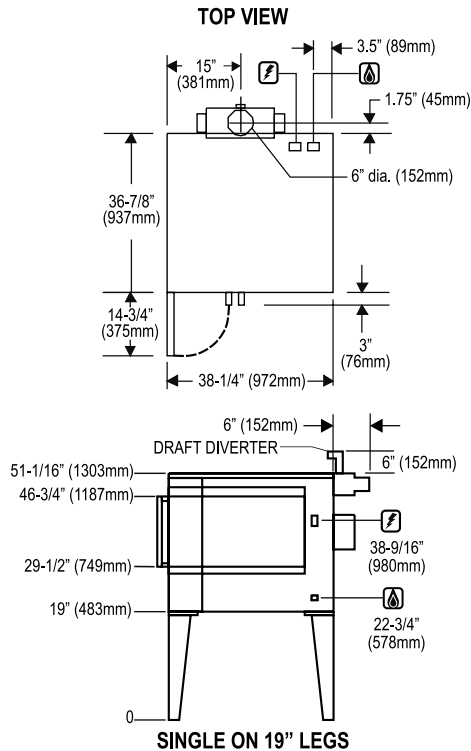

## SHORT FORM SPECIFICATIONS

Provide Blodgett full-size convection oven model SHO-G, (single/double) compartment. Each compartment shall have a fully welded angle iron frame. Interior shall have fully covered porcelainized steel liner and shall accept five 18" x 26" standard full-size bake pans in left-to-right position. Right door shall be stainless steel. Left door shall be stainless steel with dual pane thermal glass. Left door shall have chrome plated handle and dependent operation. Unit shall be gas heated with electronic spark ignition and shall cook by means of a direct fired system. Air in baking chamber distributed by dual inlet blower wheel powered by a two-speed, 3/4 HP motor with thermal overload protection. Each chamber shall be fitted with five chrome-plated removable racks. Control panel shall be recessed with Cook/Cool Down mode selector switch, electromechanical thermostat, 200 - 500°F (93-260°C), and 60-minute timer. Provide options and accessories as indicated.

## DIMENSIONS:

<b>Floor space</b>	38-1/4" (972mm) W x 36-7/8" (936mm) L
<b>Product clearance</b>	6" from combustible and non-combustible construction.
<b>Interior</b>	29" (737mm) W x 20" (508mm) H x 24-1/4" (616mm) D
<b>If oven is on casters add to all height dimensions:</b>	
Single	4-1/2" (114mm)
Double	2-1/4" (57mm)

## GAS SUPPLY:

3/4" IPS connection at rear of oven  
 Manifold Pressure:  
 • Natural – 3.5" W.C.      • Propane – 10" W.C.  
 Inlet Pressure:  
 • Natural – 7.0" W.C. min. – 10.5" W.C. max.  
 • Propane – 11" W.C. min. – 13.0" W.C. max.

## MAXIMUM INPUT:

Single	55,000 BTU/hr (16 kW)
Double	110,000 BTU/hr (32 kW)

## POWER SUPPLY:

115 VAC, 1 phase, 10 Amp, 60 Hz., 2-wire with ground, 3/4 H.P., 2 speed motor, 1725 and 1140 RPM or 1/2 H.P., 1 speed motor, 1725 RPM  
 6' (1.8m) electric cord set furnished.

## MINIMUM ENTRY CLEARANCE:

Uncrated	32-1/4" (819mm)
Crated	37-3/4" (959mm)

## SHIPPING INFORMATION:

**Approx. Weight:** Crated  
 Single: 480 lbs. (218 kg)  
 Double: 960 lbs. (435 kg)  
**Crate sizes:**  
 37-1/2" (952mm) x 43-1/2" (1105mm) x 52" (1321mm)

**NOTE:** The company reserves the right to make substitutions of components without prior notice

## BLODGETT OVEN COMPANY

www.blodgett.com

44 Lakeside Avenue, Burlington, VT 05401

Toll Free: (800) 331-5842 • Phone: (802) 860-3700 • Fax: (802) 864-0183